

PRODUCT NAME:

PVC ELECTRICAL TAPE

PRODUCT CODE/S:

AT6009 BLACK, AT6010 RED , AT6011 LIGHT GREEN, AT6012 LIGHT BLUE, AT6013 YELLOW, AT6014 WHITE, AT6015, AT6016, AT6017

KEY FEATURES:

Taking PVC film as its backing material and coating of Rubber glue, the finished PVC tape has wonderful features, such a insulation, flame retardant, cold resistance, water proof, acid&alkali resistance, etc.

USES

PVC Electrical Tape is widely used in automobile harness, wrapping of wires, insulation protection. It is the main insulation material of automobile, household electrical equipment, refrigerator, electronic apparatus, etc.

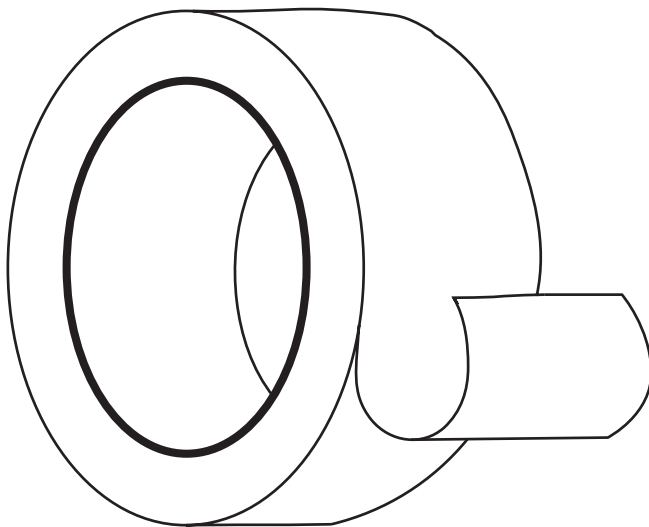
DETAILS:

MATERIAL:	PVC + ACRYLIC GLUE
ADHESION TO STEEL:	3.5~6.0N/25MM
ELONGATION AT BREAK:	150%~220%/19MM
BREAKDOWN VOTLAGE:	>4KV/MIN
TEMPERATURE TO USE:	-10°C-80°C
THICKNESS:	0.13mm, etc.
WIDTH:	19mm
LENGTH:	20m
COLORS:	Black, yellow, yellow-black, etc...
BOX QTY:	50

STORAGE

STORE UNDER NORMAL CONDITIONS OF 70°F (21°C) AND 50% R.H. IN THE ORIGINAL CARTON.