



**PRODUCT NAME:**

RASTA CUTTING STONE DISCS

**PRODUCT CODE/S:**

FLAT STONE: RA250, RA251  
DEPRESSED CENTRE: RA221, RA224

**KEY FEATURES:**

Designed for wet or dry cutting and grinding, Also used for smooth rough sides and edges  
Ideal for marble stone fiberglass, not recommended for hard granite  
Electroplated technology keeps all diamond grain attached to the steel core, high diamond exposure rate provide high efficient working performance

**MATERIAL:**

MANUFACTURED USING SILICONE CARBIDE ABRASIVE GRIT WITH FIBREGLASS REINFORCING AND RESIN BONDED

**DETAILS:**

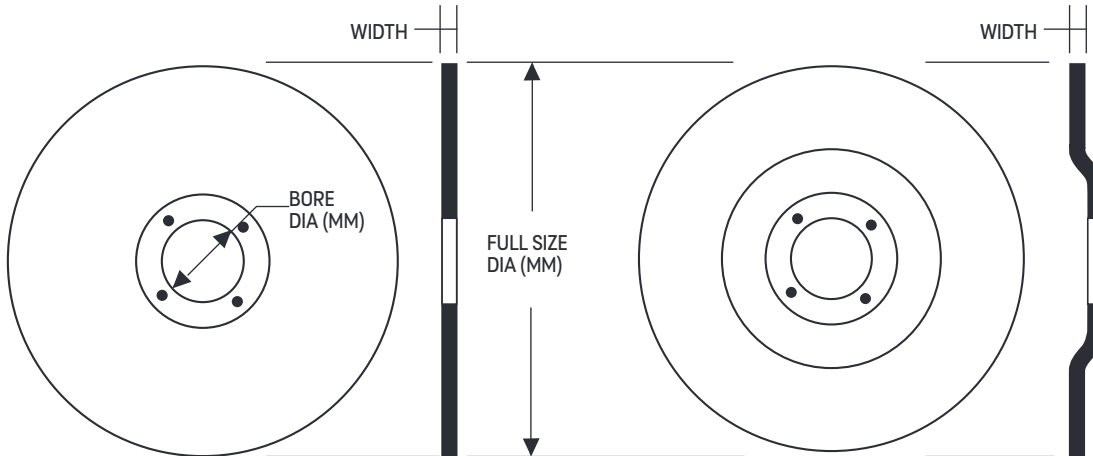

FLAT STONE CUTTING DISC

DEPRESSED CENTRE STONE CUTTING DISC

CODE	Diameter	Width (mm)	Bore (mm)	Type
RA221	115mm / 1/2"	3	22.20	DPC
RA224	230mm / 9"	3	22.20	DPC

**STORAGE**

A SAW WITH A MISALIGNED HEAD, WORN BLADE SHAFT BEARINGS, WORN BLADE FLANGES, WORN BELTS OR PULLEYS, OR IMPROPERLY TRACKING CONVEYOR CART, WILL GENERALLY STILL CUT MATERIAL, BUT PUTS STRESSES ON THE BLADE THAT WILL RESULT IN CUTS THAT ARE NOT SQUARE. THIS WILL ALSO CAUSE A SHORT BLADE LIFE OR A BLADE THAT WEARS UNEVENLY.

